

DH-PFA130-E

Water-proof Junction Box



Features

- Neat & Integrated design
- Material: Aluminum
- IP66 junction box

Technical Specifications

Model	DH-PFA130-E
General	
Material	Aluminum
Dimension	Φ124mmx41mm(Φ4.88"x1.61")
Pipe thread	G3/4"
Weight	0.35kg(0.77lb)
Load bearing	3.0kg(6.61lb)
Color	White
Protection	IP66
Operating temperature	-40°C ~60°C(-40°F ~+140°F)
Humidity	<90% RH
Applicable model	Please see "Accessory Selection"

Order Information

Type	Part Number	Description
Camera mount	DH-PFA130-E	Water-proof junction box
	PFA130-E	Water-proof junction box

Dimensions (mm/inch)

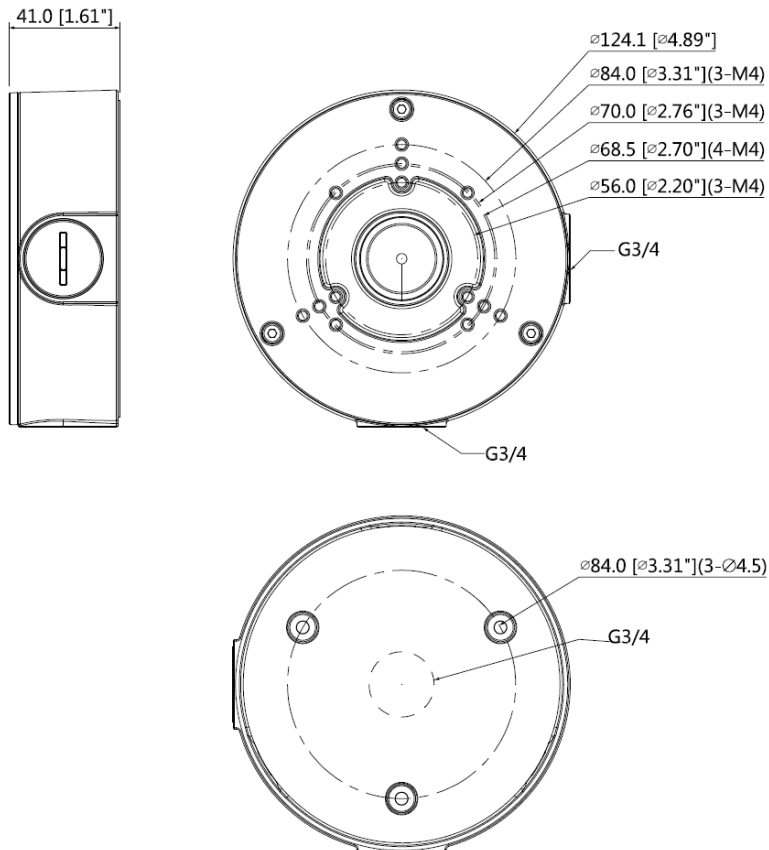

Application

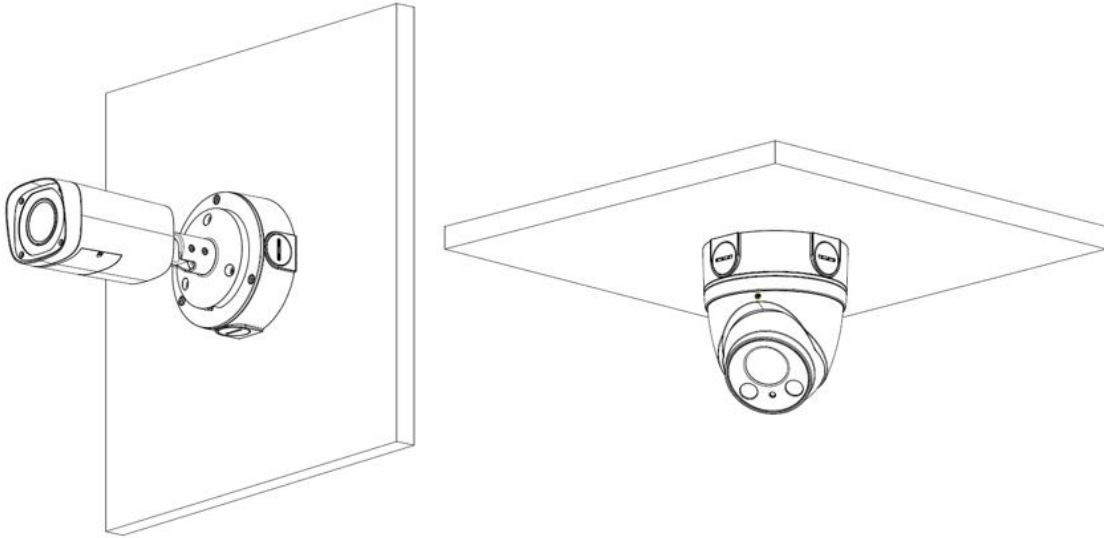

Package Information

- Water-proof junction box DH-PFA130-E *1
- M4x10 screw *4
- ST4.2x25 screw *3
- Plastic Anchor: 3
- Mounting sticker *1
- S3.0 wrench *1